

TYPE OF CAR	CLASS	SERIES	BUILT BY	YEAR
FLAT (TOFC)	FT-II	90100-90123 90164	A.T.S.F. (TS)	1958

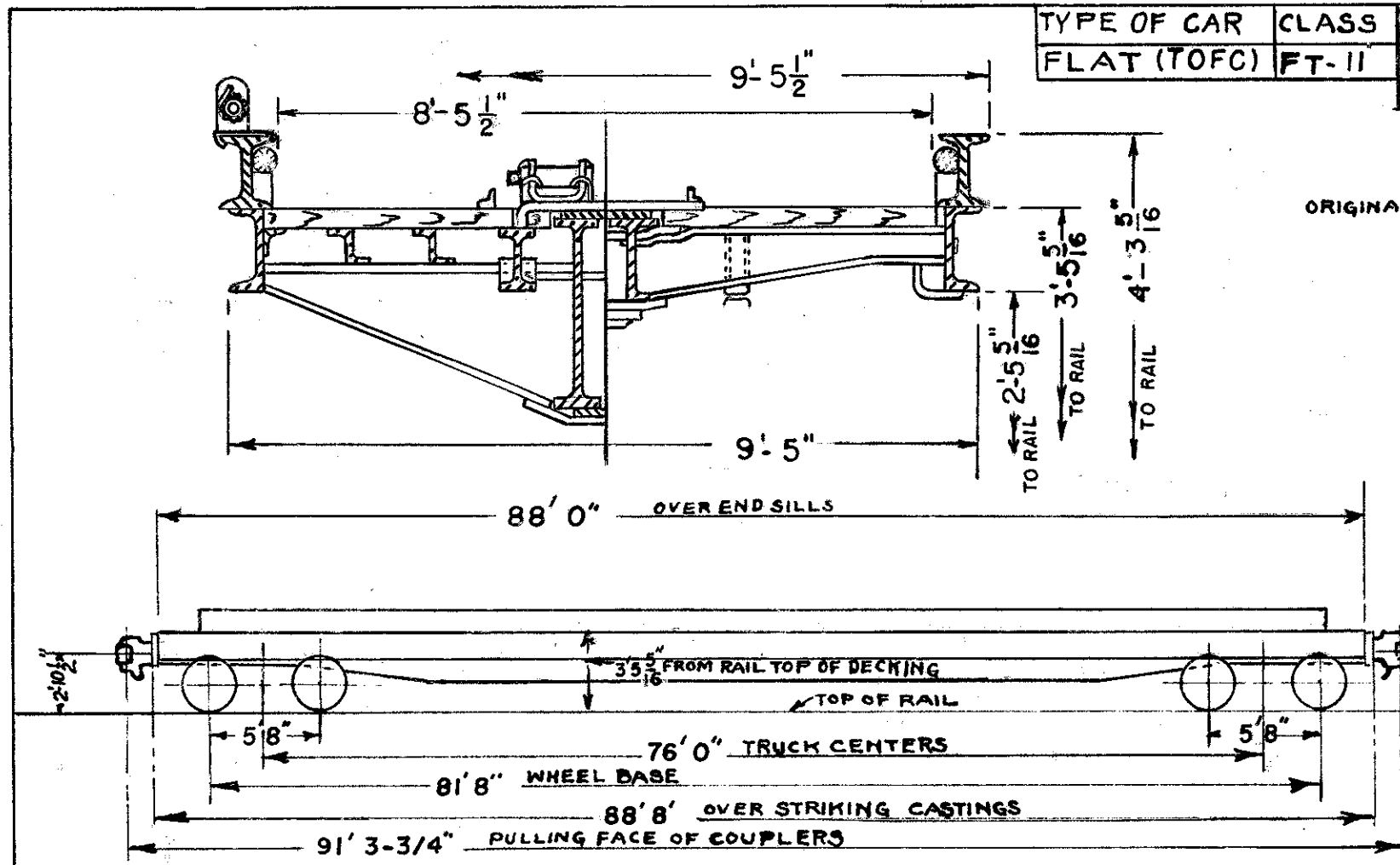

ORIGINAL NUMBER OF CARS - 25

DRAWN	
TRACED	
CHECKED	
DATE OF REVISIONS	
6-28-61	

TRUCK JOURNALS ARE EQUIPPED WITH A.B.S. CO. CARTRIDGE BEARING, TYPE 3A, PER CAR FOLIO PAGE 555-C-1.

**DESCRIPTION**

CAPACITY	117 000 LBS.	WIDTH BETWEEN GUARD RAILS	8' 5-1/2"
LOAD LIMIT	117 100 LBS.	WIDTH OVER GUARD RAILS	9' 5-1/2"
LIGHT WEIGHT OF CAR	92 900 LBS.	EXTREME WIDTH (GUARD RAILS)	9' 5-1/2"
WEIGHT OF BODY		HEIGHT FROM RAIL TO EXTREME WIDTH	4' 3-5/16"
WEIGHT OF TRUCK			
HEIGHT FROM RAIL TO TOP OF FLOOR	3' 5-5/16"	UNDERFRAME (ALL WELDED)	STEEL
LENGTH OVER END SILLS	88' 0"	KIND OF COUPLERS	TYPE "E" ROTARY, SWIVEL SHANK
LENGTH OVER STRIKING CASTINGS	88' 8"	SIZE OF SHANK	6-1/4" X 8"
LENGTH OVER PULLING FACE OF COUPLERS	91' 3-3/4"	DRAW BAR YOKE	Y-30 VERTICAL SWIVEL
CENTER TO CENTER OF TRUCKS	76' 0"	DRAW BAR ATTACHMENT	SINGLE, HORIZ, KEY
WHEEL BASE OF CAR	81' 8"	UNCOUPLING ARRANGEMENT	S. R. E. M. CO.
WIDTH OVER SIDE SILL PLATES	9' 5"	HAND BRAKE	(DROP SHAFT TYPE) UNIVERSAL
DRG. LIST - BODY	213/3358		
DRG. LIST - TRUCK	213/3312		
BILL OF MATERIAL	1010		

DRAFT GEAR	NAT. MALL. MF-400
KIND OF TRUCK	BUCKEYE, 3-11/16" SPR. TRAVEL
WHEEL BASE OF TRUCK	5' 8"
TRUCK FRAME	CS-2945 DRG. 20-A-2709
TRUCK BOLSTER	CS-2946 DRG. 20-A-2710
SIZE OF JOURNAL	6 X 11"
WHEELS	ONE-WEAR WROT STEEL
BRAKE BEAM	A. S. F. #24 UNIT TYPE
BRAKES	AB DUAL SYSTEM 10 X 12 WEST HSE
SPRINGS	3010, 3011, 3072, 3073

