

Part 3
RTR CONVERSION

IHC USRA 4-6-2

to

1050 Class 2-6-2

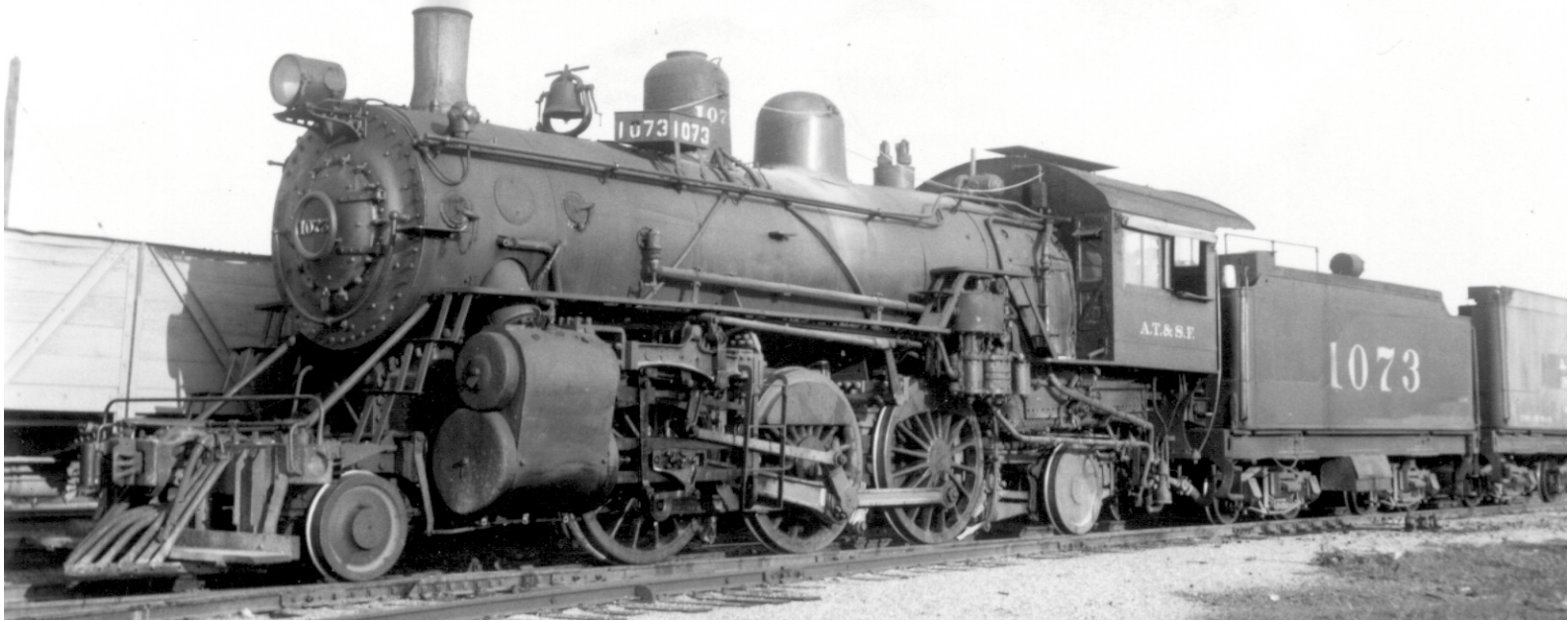
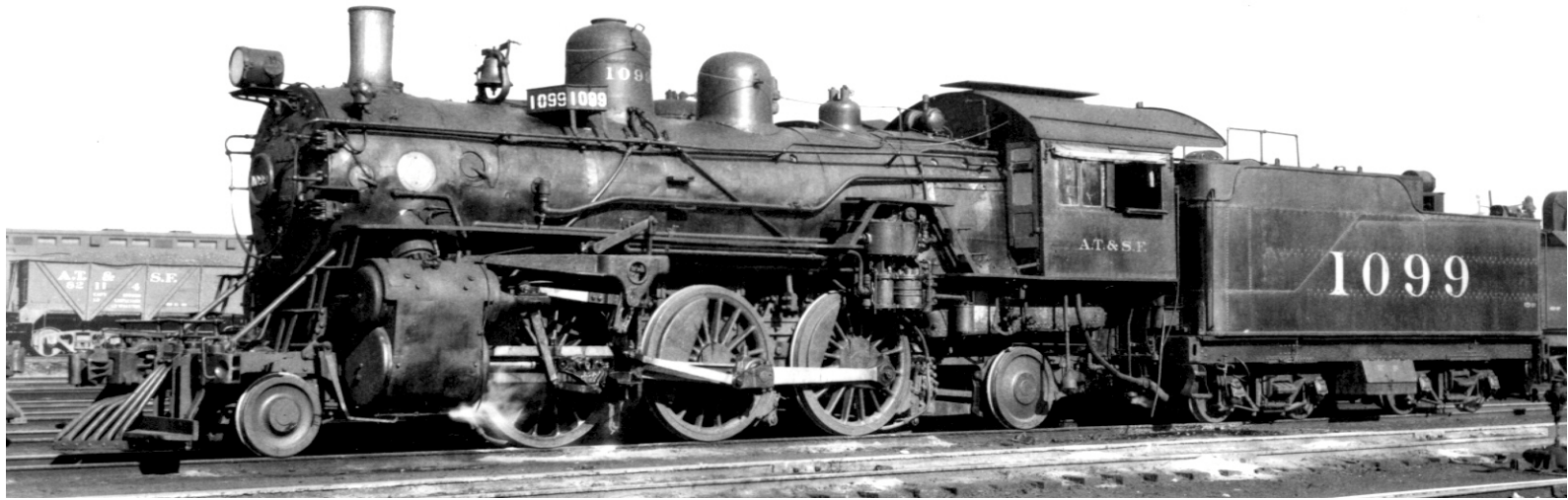

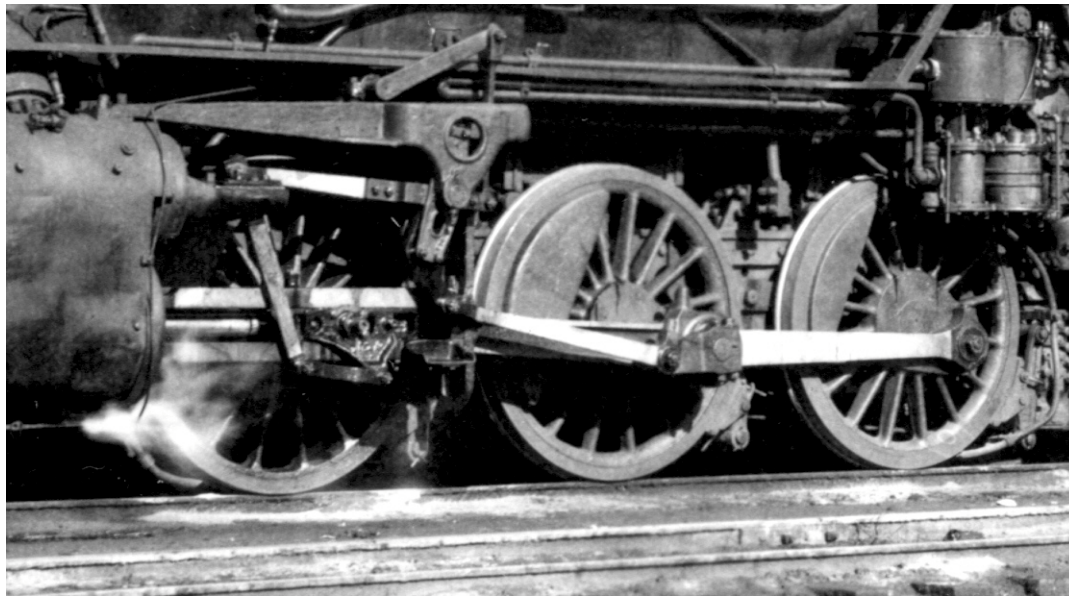

Walschaerts Valve Gear

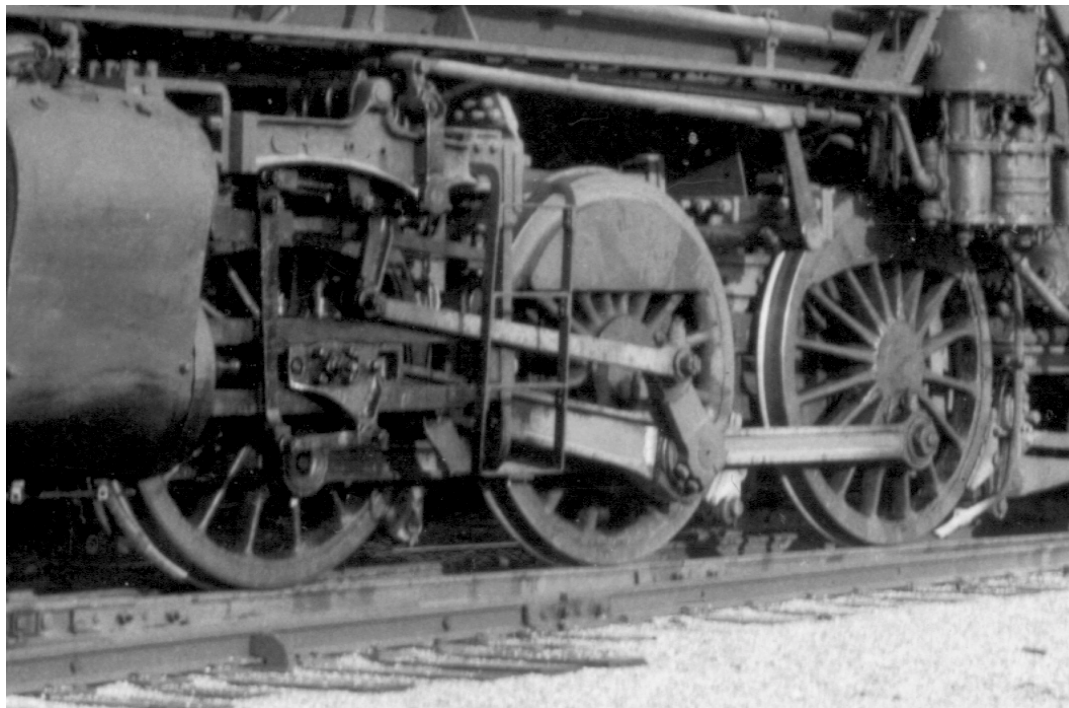

Baker Valve Gear

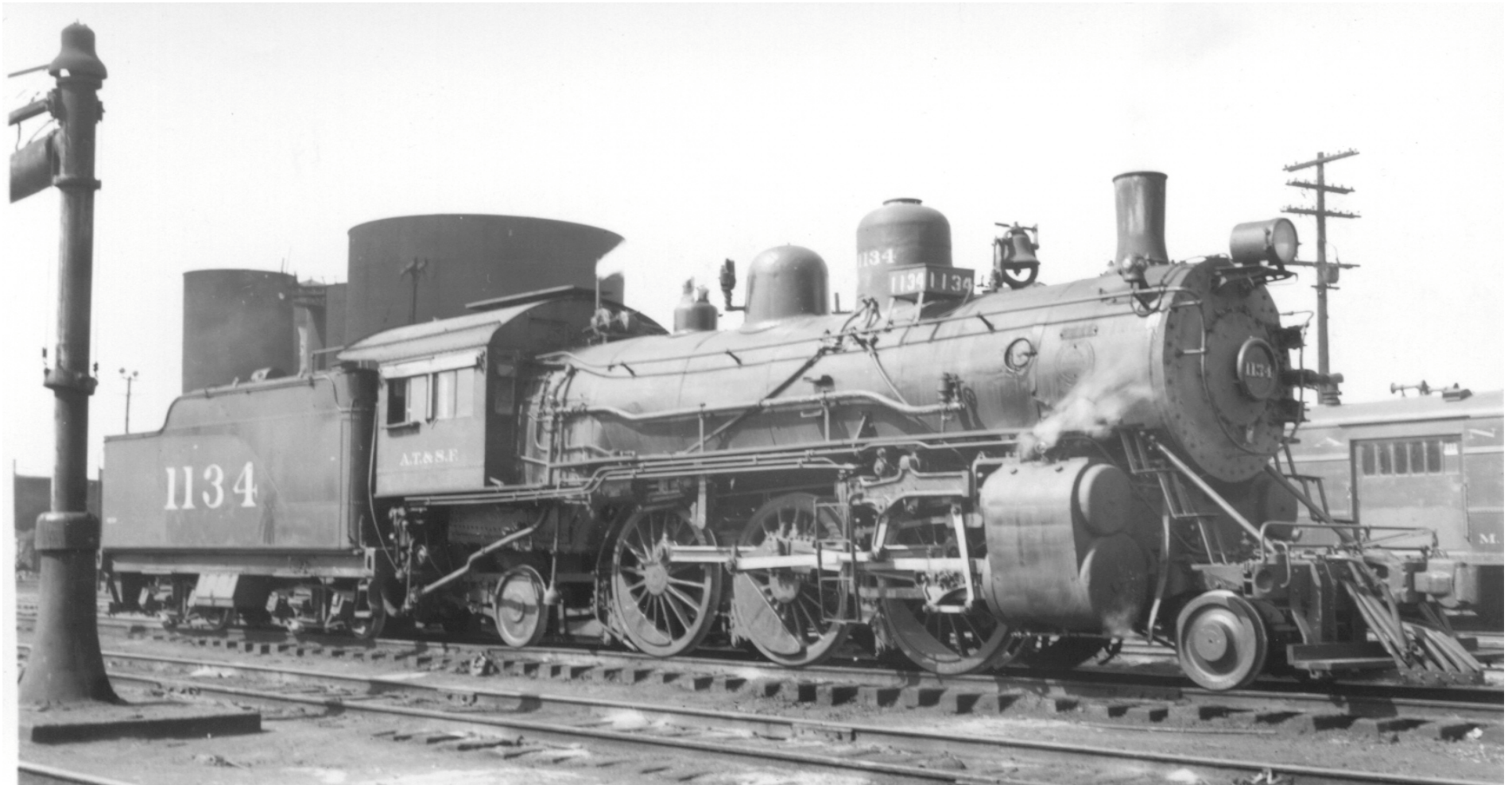

Tender Badge 1481
1910 design
3129 G.O. S.564
9000 G.W.

1946 KC
C. Winters photo

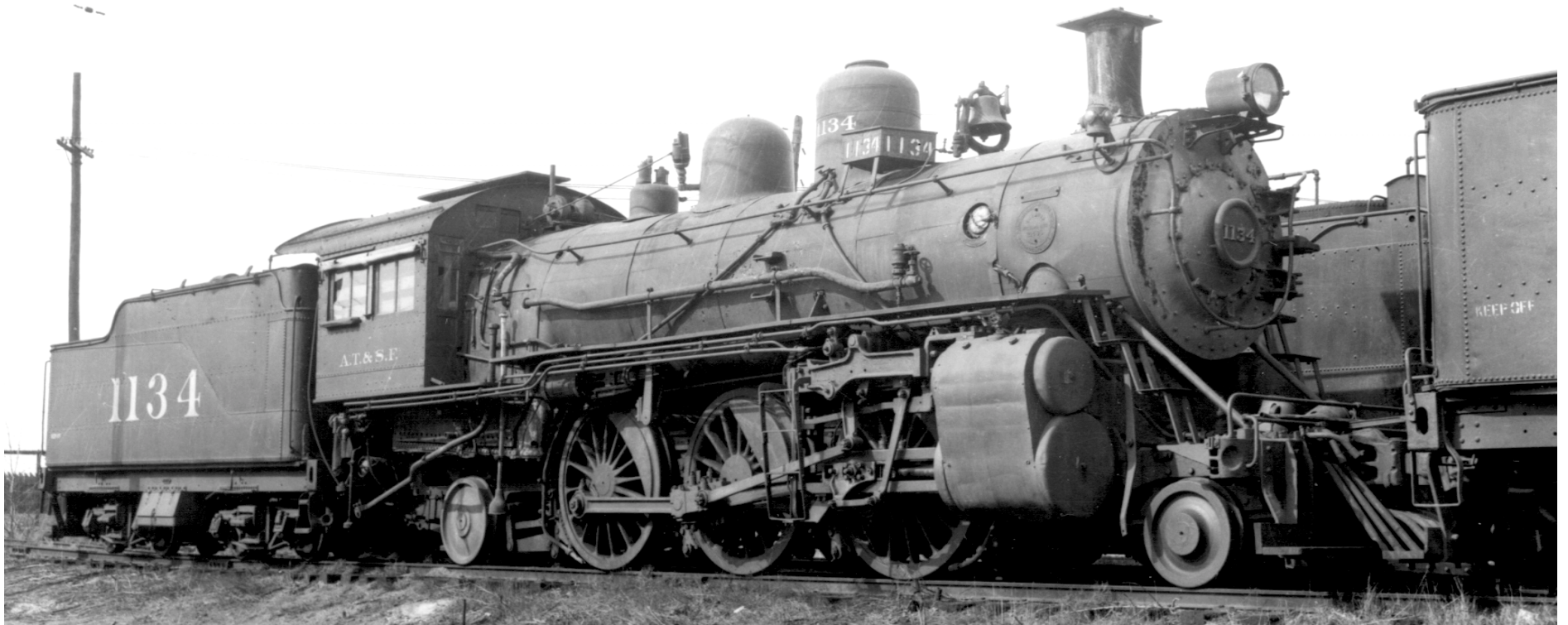

1948 KC
A. B. Johnson photo



Tender badge 3317
Built 1911
3129 G.O. S.564
9000G.W.

Amarillo 1936
Otto Perry photo



1010 Amarillo 4-17-1937 Otto Perry photo

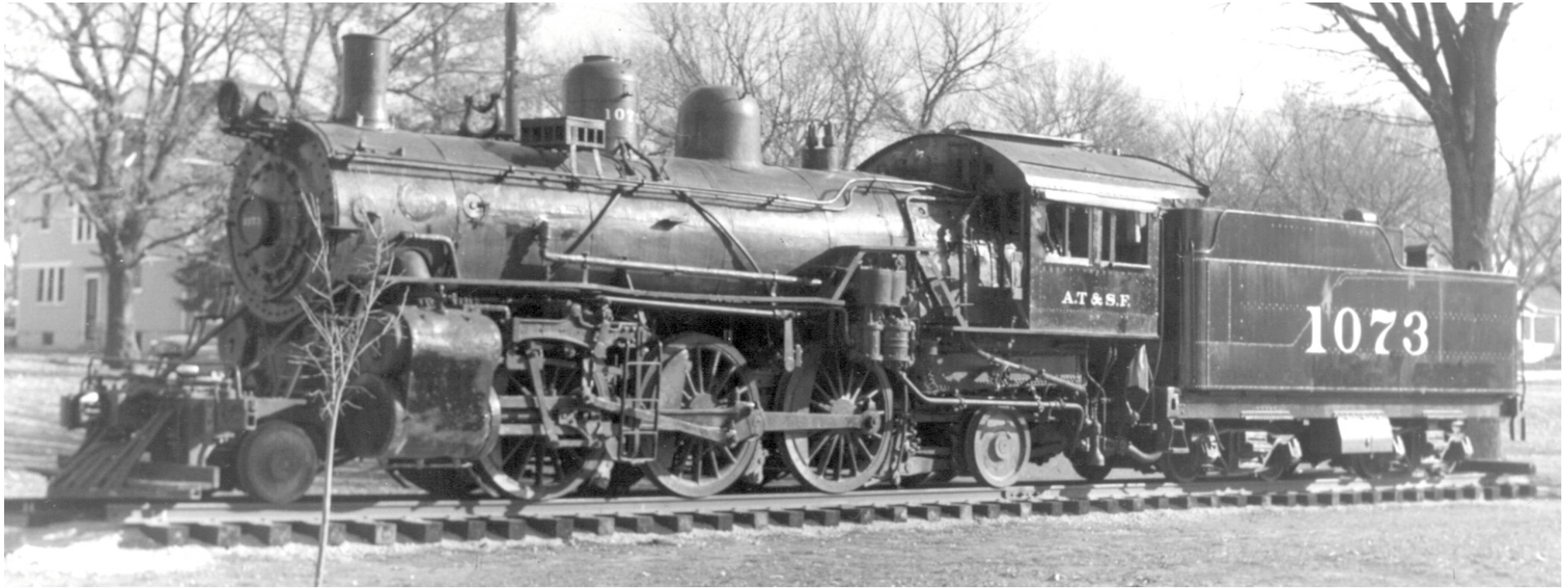

Tender badge 1605
Built 1905
3129 G.O. S. 564
8500 G.W.

1955 Lawrence
Evans photo

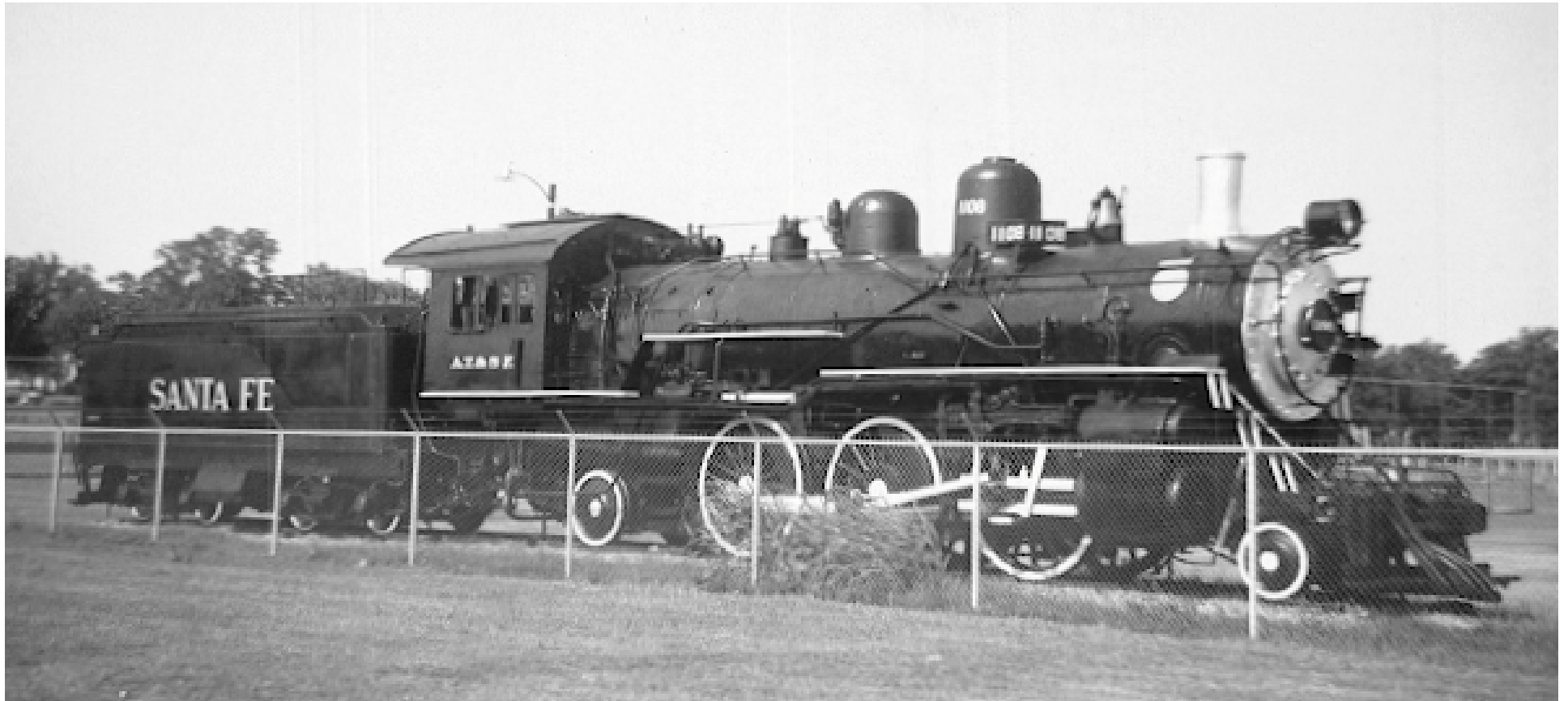

1108 (extended cab) on display Ardmore OK

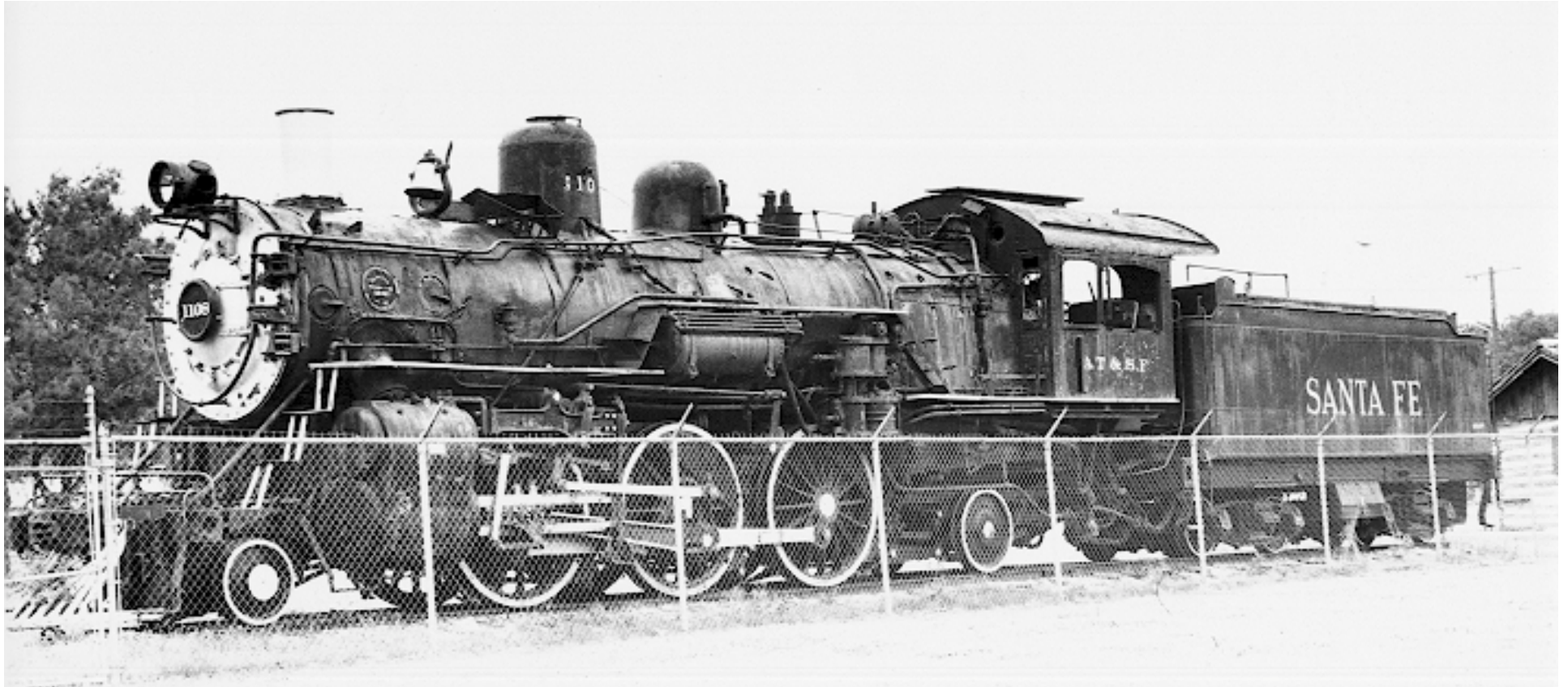

1108 on display at Ardmore (extended cab)



Texas locomotives to model

1132 Baker valve gear

tender badge 1864 - 1907 design

3129 G.O. S. 564

9000 G.W.

1135 Baker valve gear

tender badge 3317 - 1911 design

3129 G.O. S. 564

9000 G. W.

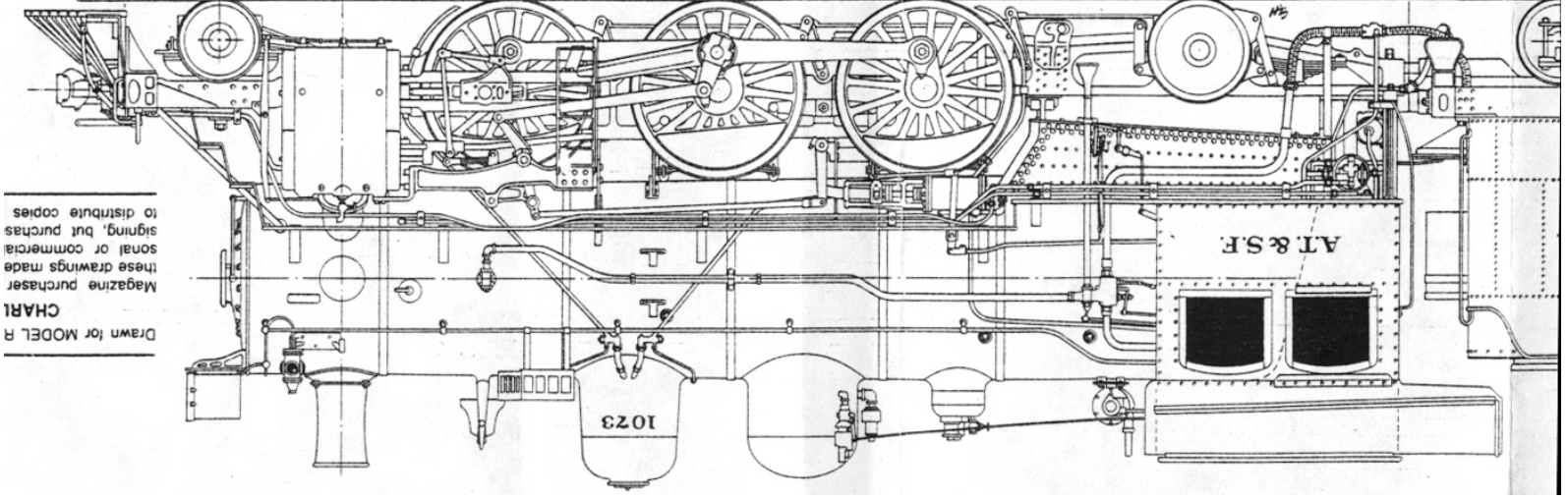
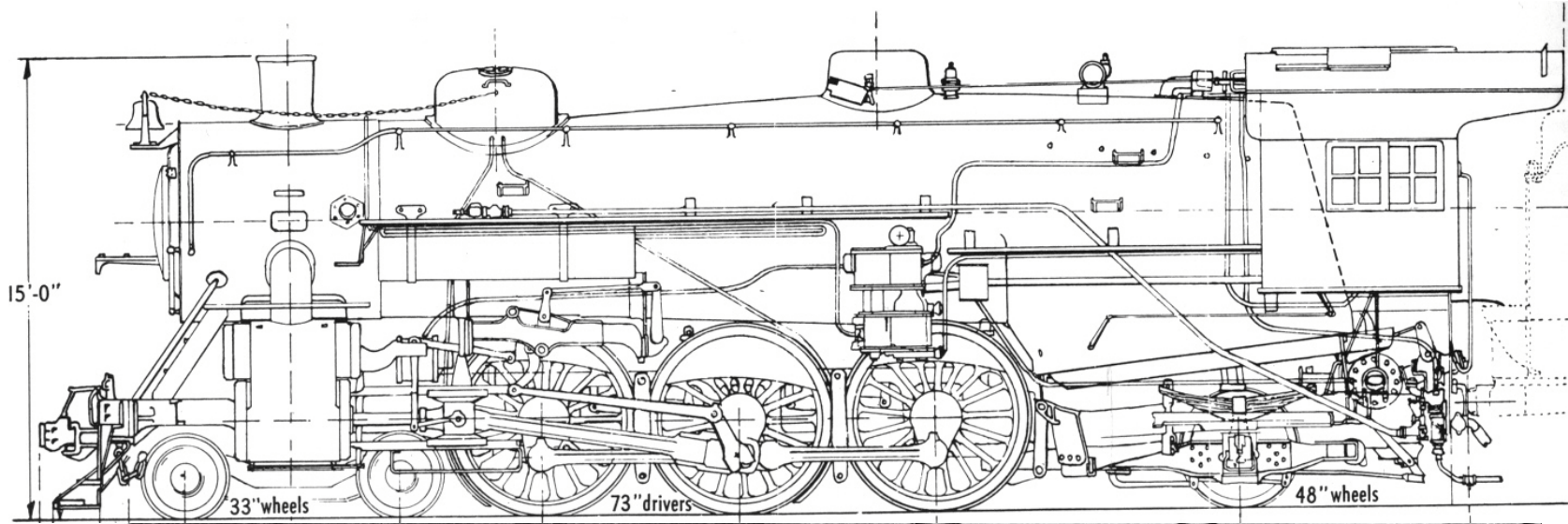

Drawn for MODEL R
 CHARI
 Magazine purchaser
 these drawings made
 sonal or commercial
 signing, but purchas
 to distribute copies

Shorten the cylinder to first driver distance

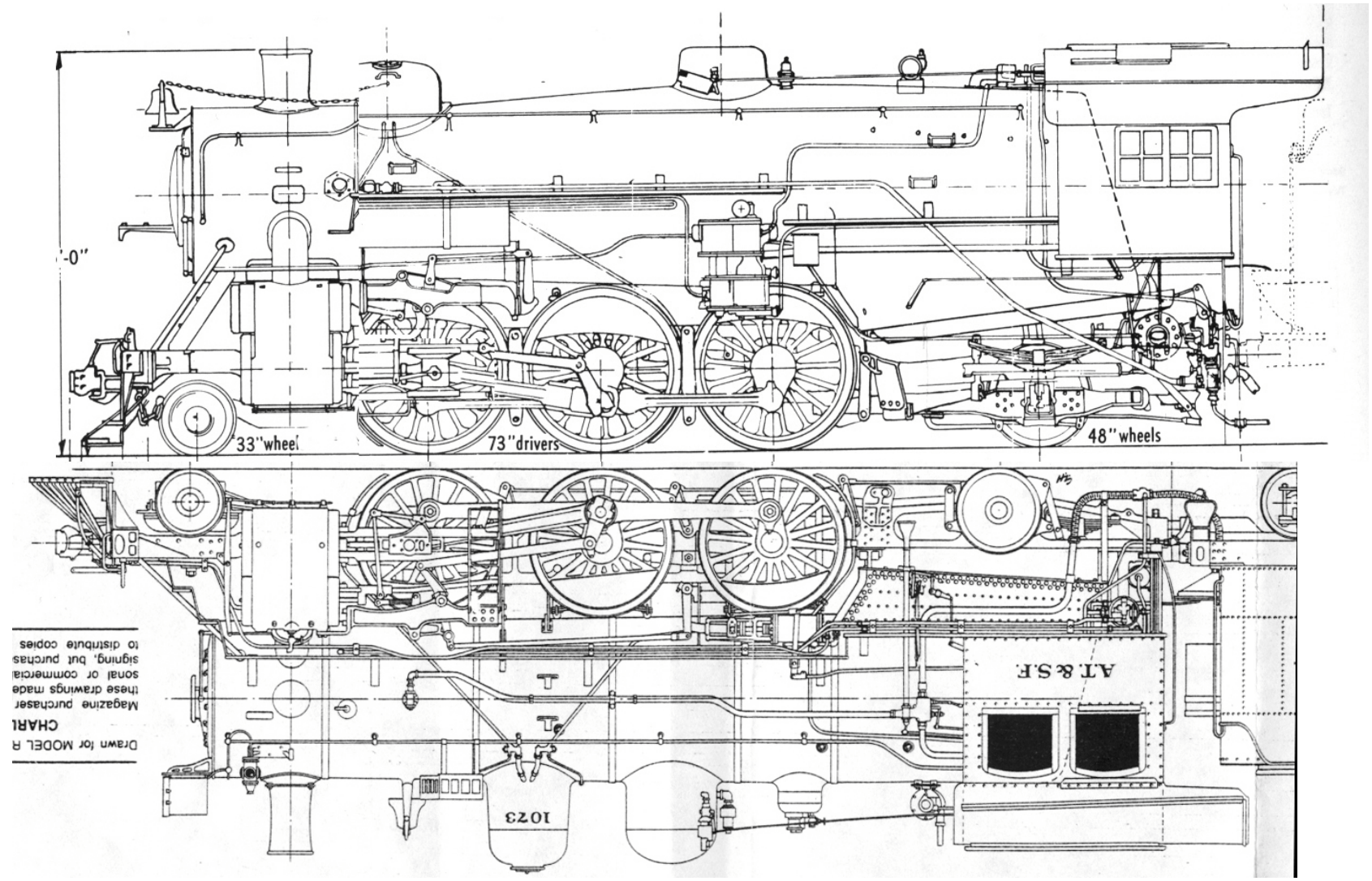

Drawn for MODEL R
CHARI
Magazine purchaser
these drawings made
sonal or commercial
signing, but purchas
to distribute copies

omotives

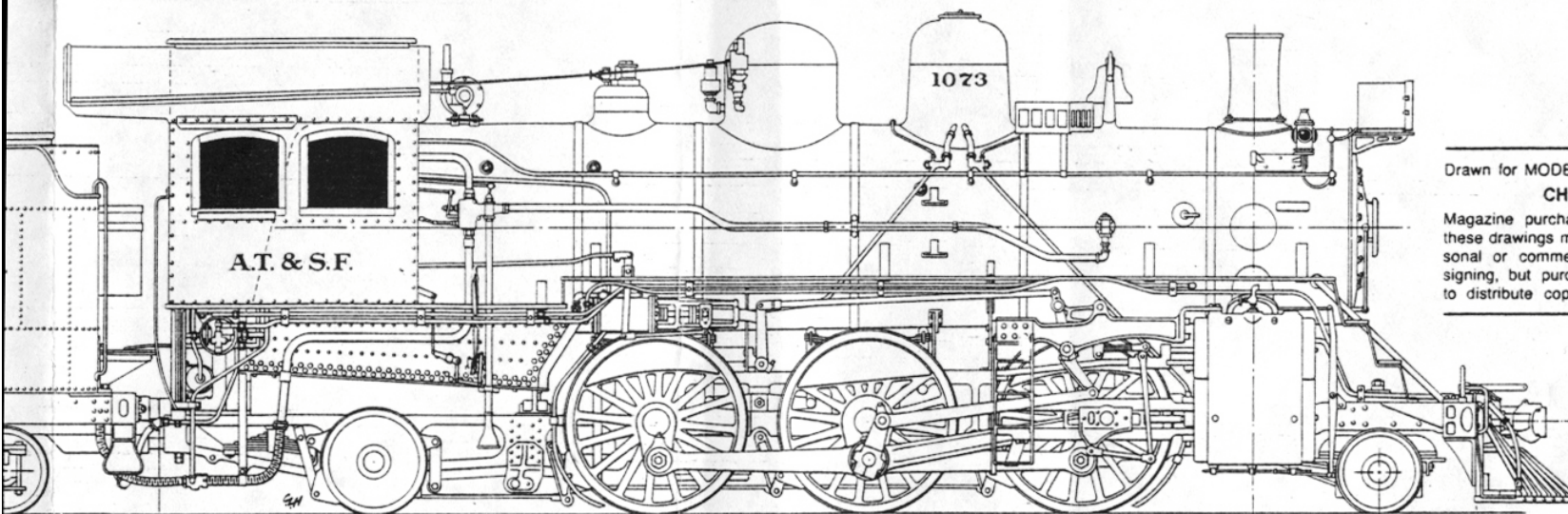
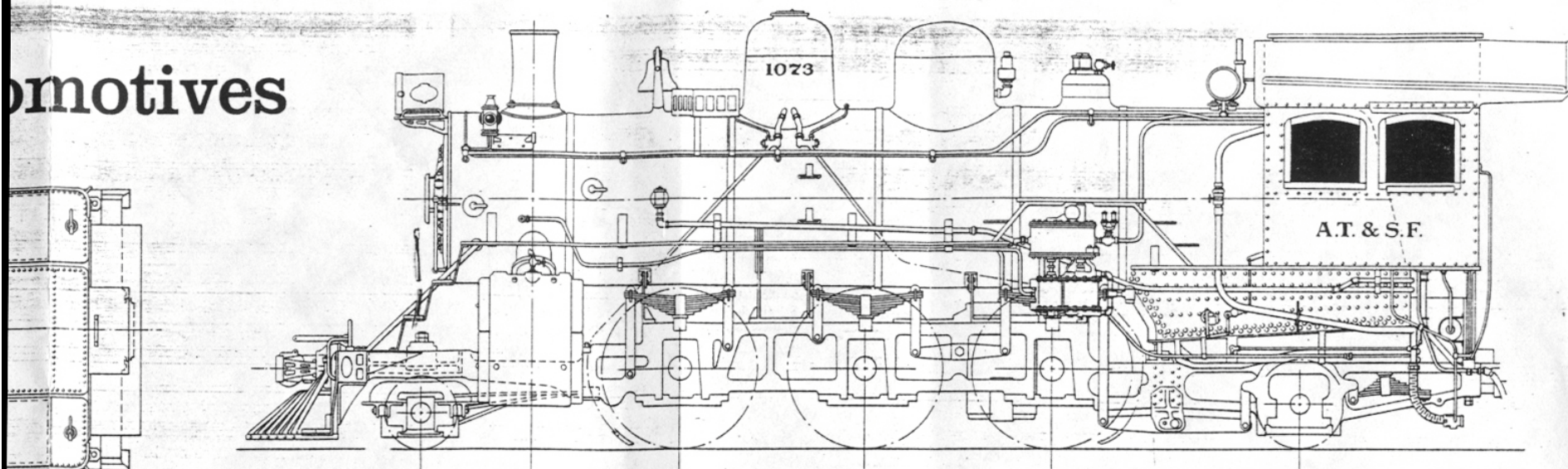

Drawn for MODEL RAILROADER MAGAZINE by
CHARLES HANSEN

Magazine purchaser may have photocopies of these drawings made locally as an aid to his personal or commercial modelmaking or tool designing, but purchaser does not have the right to distribute copies of the drawings to others.

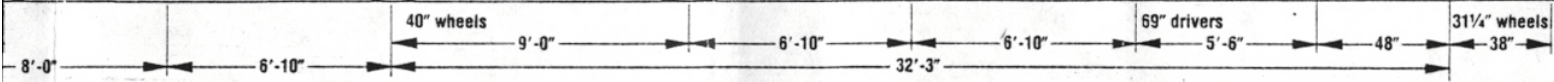

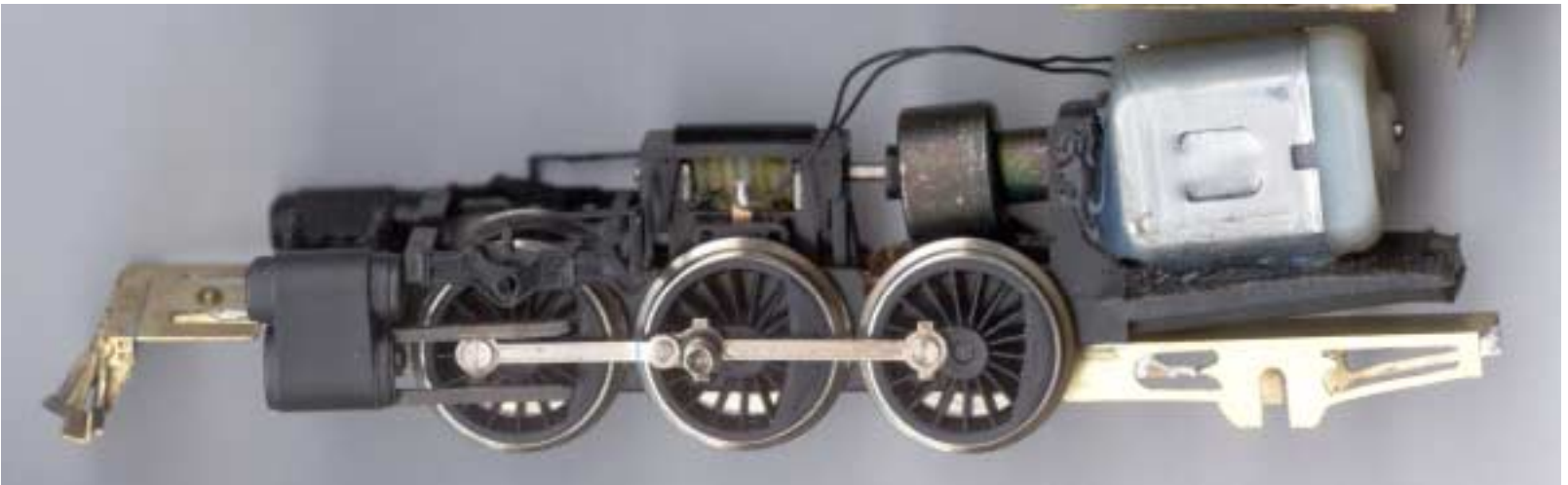
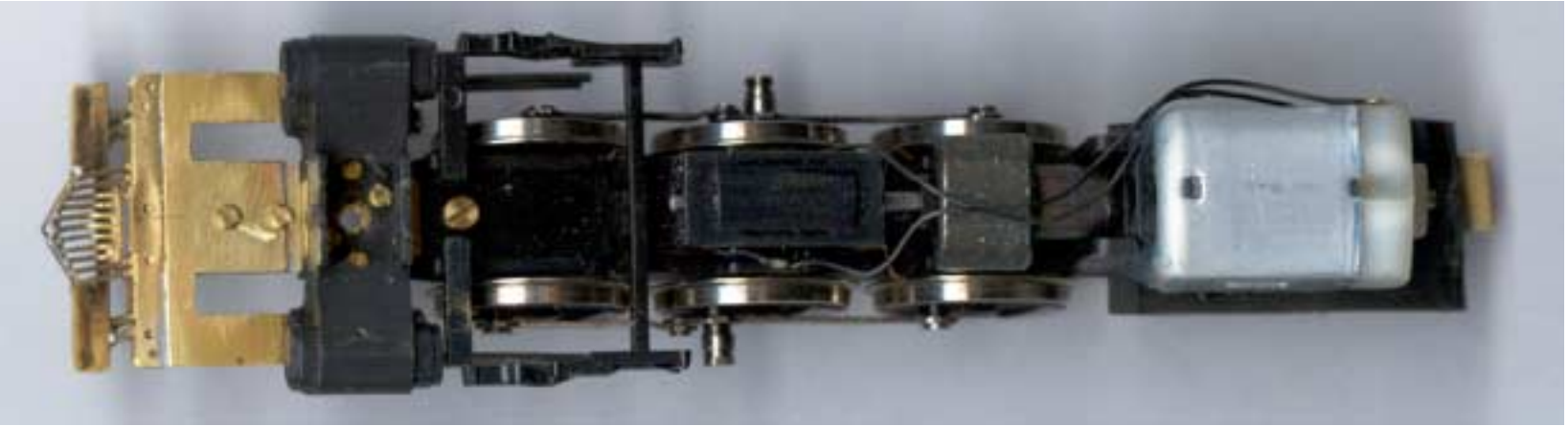

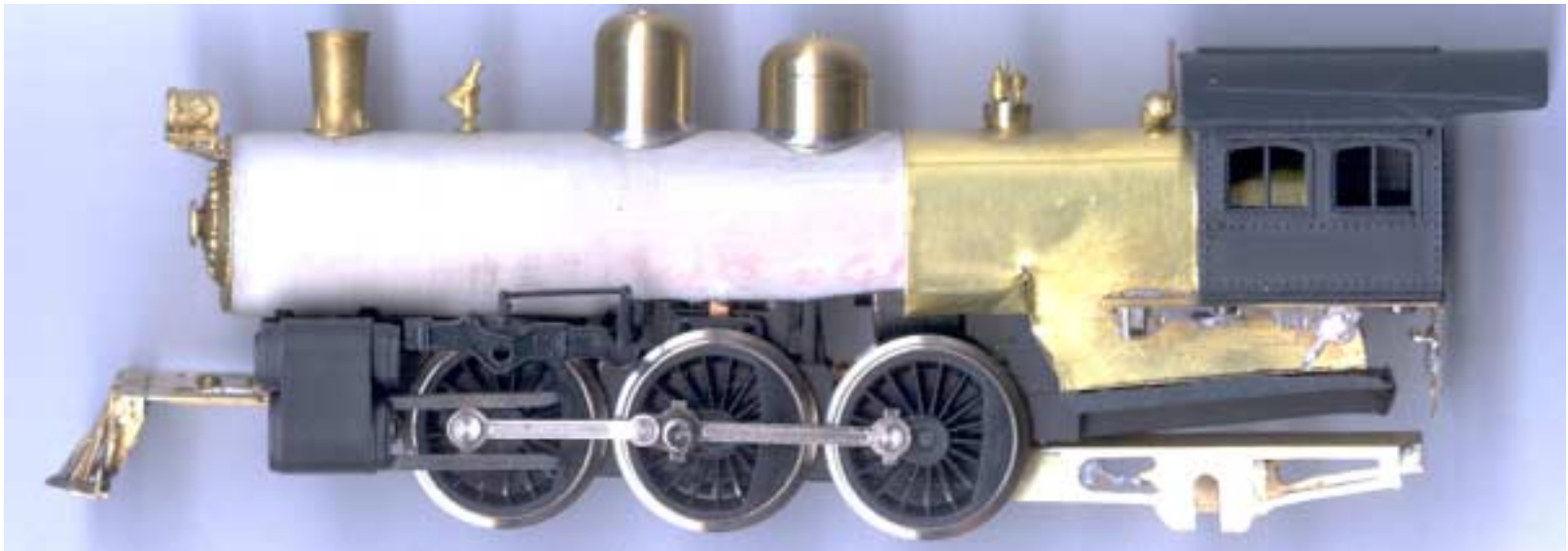
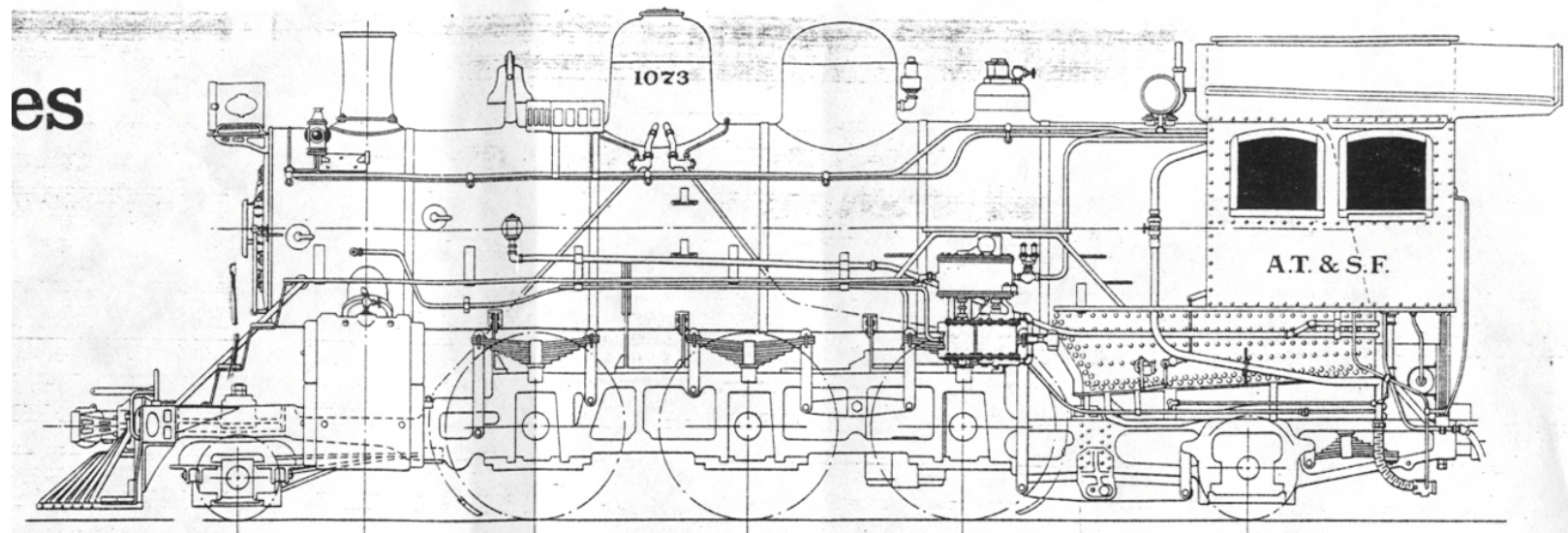

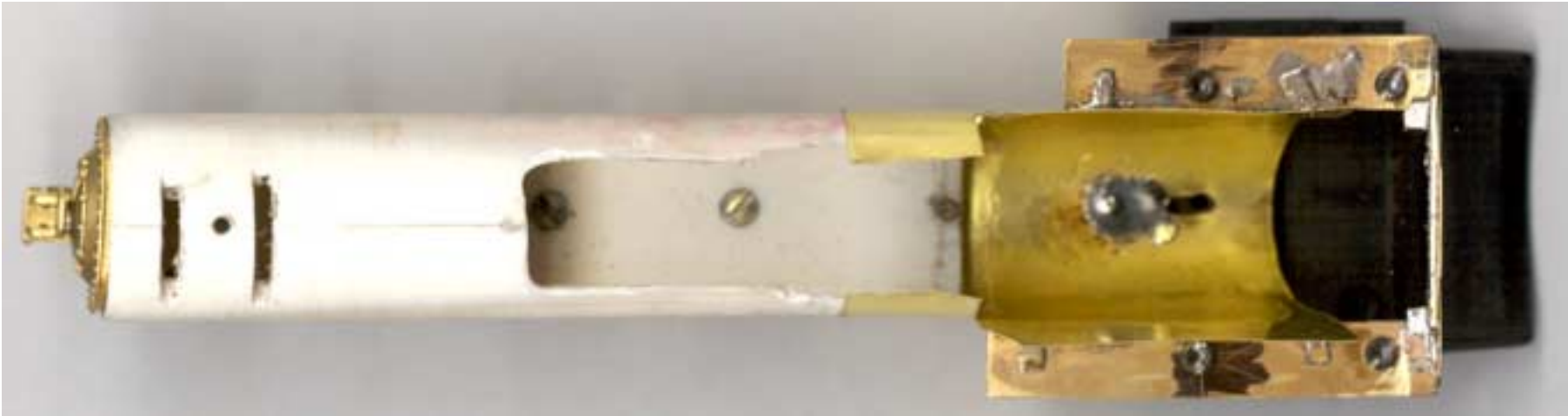



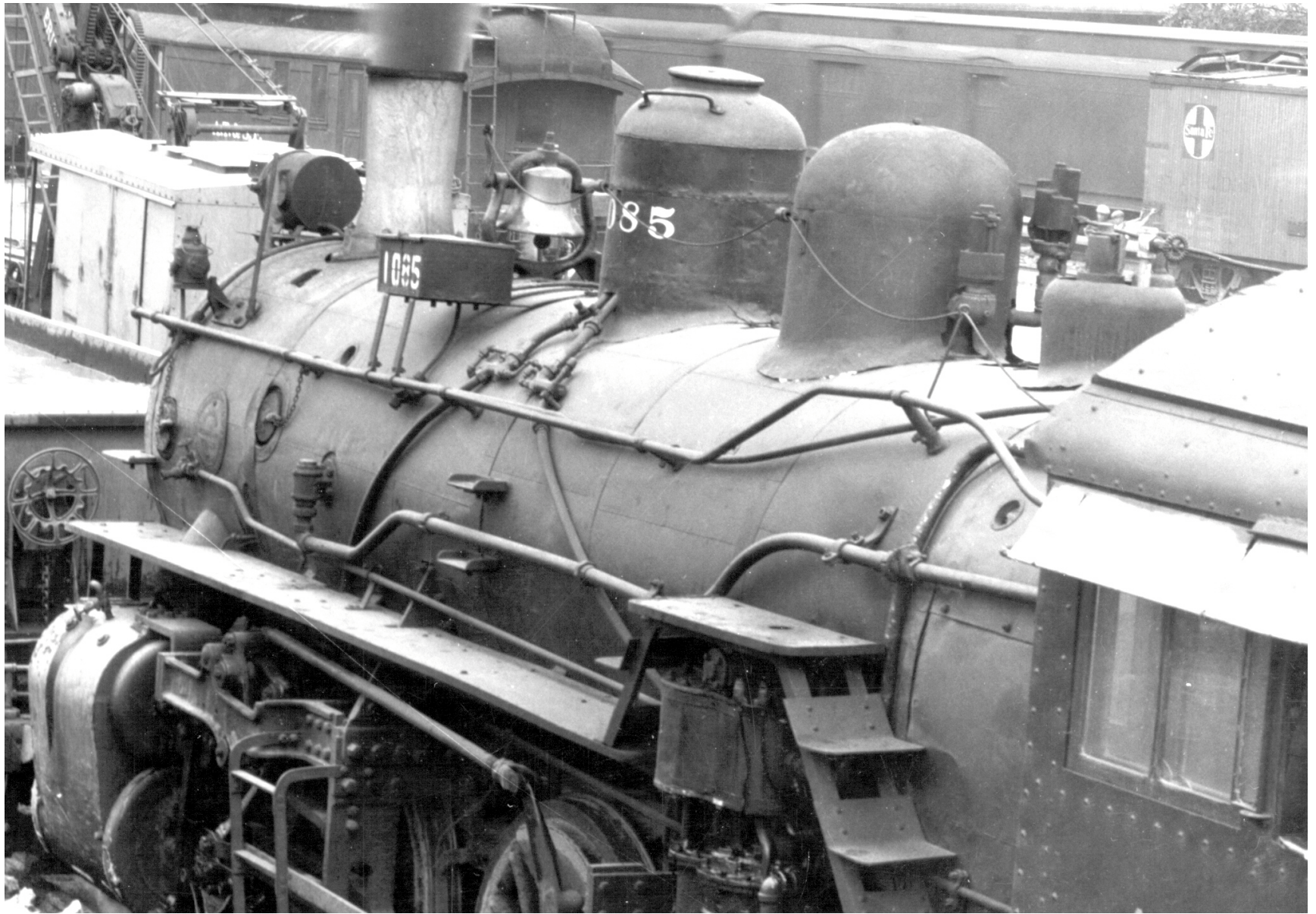







Tender badge 1880
Built 1907
3604 G.O. S. 699
9000G.W.

1880 on display at Newton
Ca 1960





West Texas shipment – peanuts?